

Framed Standard Construction

- 1 Front Frame**
 $\frac{3}{4}$ " thick kiln dried solid hardwood. Bore and dowel or pocket screw frame joinery reinforced with glue and nails. Stiles and rails are $1\frac{1}{2}$ " wide. Mullions are 3" wide. Stiles dadoed to receive ends. Rails dadoed to receive tops and bottoms.
- 2 End Panels**
Standard: Nominal $\frac{1}{2}$ " (12mm) thick wood based composite panel with matching laminate exterior surfaces. Cabinets will come with natural maple laminate interiors. All end panels are inserted into dado in face frame and recessed $\frac{1}{4}$ ".
Upgrade: Nominal $\frac{1}{2}$ " (12mm) thick multi-ply hardwood plywood with maple veneer (stain finishes) or matching laminate (paint, thermofoil and thermofused melamine finishes) on exterior surfaces and hardwood veneer on interior surfaces. All end panels are constructed with the same dado joinery as above and are recessed $\frac{1}{4}$ ".
- 3 Top/Bottom Panels**
 Nominal $\frac{1}{2}$ " (12mm) thick wood based composite panel with natural maple laminate exterior and interior surfaces for wall cabinets and interior surfaces for base cabinets. Tops and bottoms are set into grooved end panels and front rails, glued and stapled. Bottoms are supported at rear of base cabinet by nominal $\frac{1}{2}$ " (12mm) thick wood base composite panel.
- 4 Hanging Rails**
 Constructed from nominal $\frac{1}{2}$ " (12mm) thick x $4\frac{1}{4}$ " high wood based composite panel. Hanging rails run the full cabinet width at top for all cabinets; wall cabinets receive an additional hanging rail at the bottom. Hanging rails are captured between end panels and are recessed behind the back panel for all cabinets.
- 5 Back Panel**
 Nominal $\frac{1}{8}$ " (3mm) thick hardboard with natural maple laminate interior surface. Securely hot glued and stapled to hanging rails. Back panels are fully captured on wall cabinets.
- 6 Shelves**
 $\frac{3}{4}$ " thick wood based composite panel with natural maple laminate on both faces and matching edge band on front edge. Shelves are adjustable in all standard cabinets. Wall and tall cabinets receive full-depth shelves, base and vanity cabinets receive half-depth shelves.
- 7 Toe Kick**
 Nominal $\frac{1}{2}$ " (12mm) thick unfinished wood based composite panel captured between end panels. Toe kick is $4\frac{1}{2}$ " high and recessed $3\frac{1}{2}$ ".
- 8 Base Corner Braces**
 High impact injection molded plastic. NOTE: Drawings in this manual may not reflect corner braces.

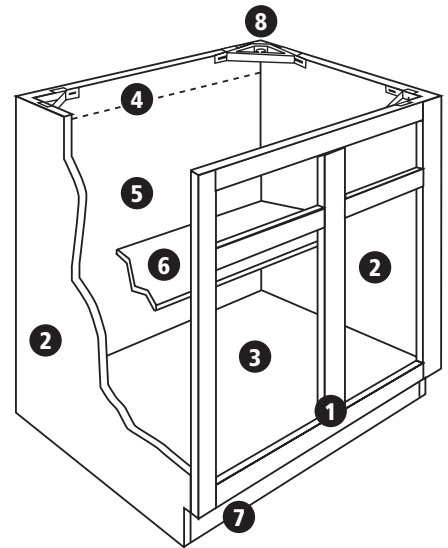
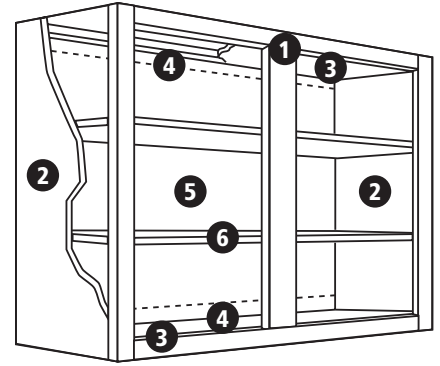

Drawers

Front, back and sides are nominal $\frac{5}{8}$ " (16mm) thick hardwood with dovetail construction. Drawer bottoms are a nominal $\frac{1}{4}$ " (6mm) plywood veneer; bottoms are inserted into dado in front, back and sides.

Drawer Guides

Standard: Guides feature high-quality epoxy coated steel with self-adjusting in mounting brackets. Also includes built-in stop, self-closing and stay-closed features with a 75 lb rated load capacity.

Upgrade: High-quality steel, undermount construction provides full drawer access. Self-adjusting in mounting brackets. Built-in stop, self-closing and stay closed features with a 75 lb rated load capacity. Provides soft-close feature that helps reduce drawer slamming.

Hinges

Standard: Heavy-duty, high-quality steel, concealed 6-way adjustable hinge with self-closing feature.

Upgrade: Gentle-Touch (soft-close) hinge – heavy-duty, high-quality steel, concealed 6-way adjustable hinge with soft-close resistance.

NOTICE: The product specifications appearing herein supersede and cancel all previous sheets, supplements and addenda, and represent current manufacturing standards and procedures. We reserve the right to make specification changes for continued product improvement. For aesthetic considerations the furniture and cabinet industries have made veneer on composite panel substrate the standard method of construction for raised panel-in-frame doors in some wood species. Within this product line, this includes orders in maple species.